

IMPORTANT:
The "User Operating Card"
must be left
with Visidec Focus Articulated
Arm Double once installed



VF-AT-D / FOCUS ARTICULATED ARM
DOUBLE

Installation Instructions

A Component Checklist - Check you have received all parts against the component checklist prior to installing

Double Arm Assembly

Pole Assembly

User Operating Card
(see note at top of page)

Desk Clamp Box

Desk Clamp Bracket Pressure Plate M8 Desk Clamp Screw 5mm Allen Key

BitsBox

Primary Arm Cable Cover (x2) Pole Top Cap M8x30mm Screw CableClip (x2)

Secondary Arm Cable Cover (x2) Bolt Through Base Cable Balls (x2) Steel Washer

Display Mounting Screws

M4x10mm (x 8)
M4x12mm (x 8)
M4x16mm (x 8)

B1 Bolt Through

Drill a 9mm ($\frac{3}{8}$ ") hole in the work surface at the desired position and assemble as shown below.

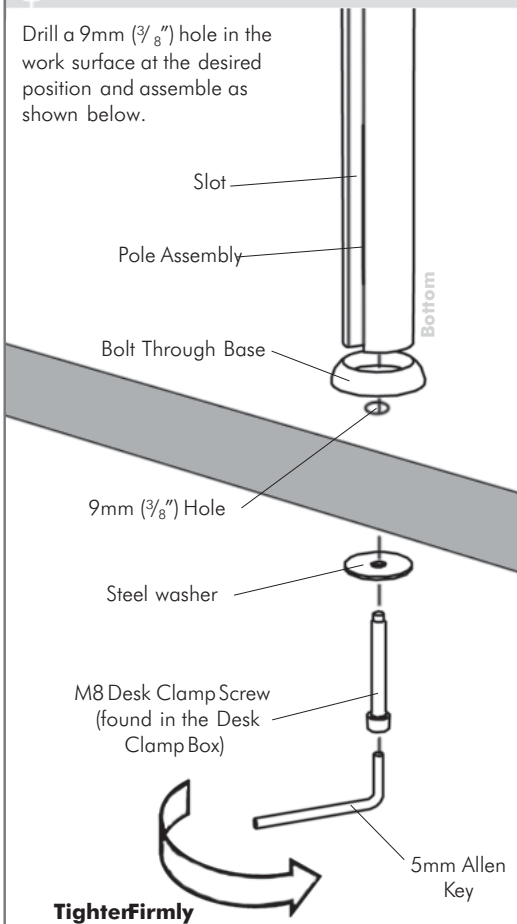

NOTE:
Ensure the slot in the Pole Assembly faces away from the user.
It is recommended that the Pole Assembly be mounted towards the rear edge of the work surface

B2 Desk Clamp

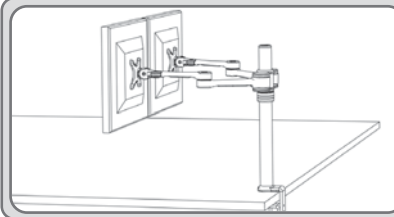

NOTE: When using the Desk Clamp mounting option, the displays can **only** be used in side by side configuration as shown. Failure to do so may result in serious damage to product and displays.

Step 1: Attach the Desk Clamp Bracket to the bottom of the Pole Assembly using the M8x30mm Screw. **Tighten firmly** using the 5mm Allen Key. Ensure the Visidec logo is facing the front as shown.

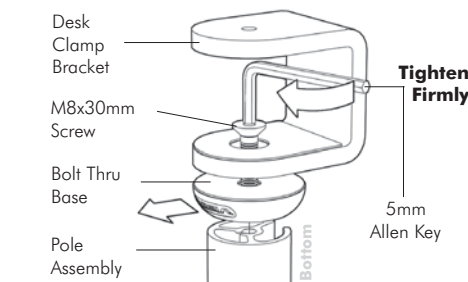

Step 2: Install the M8 Desk Clamp Screw and Pressure Plate as shown.

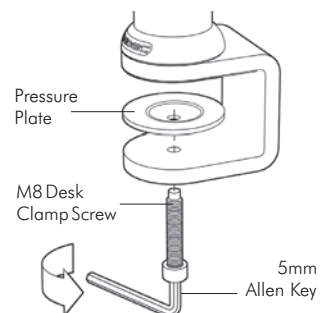

Step 3: Adjust the height of the Pressure Plate to suit the Work Surface and tighten firmly in the desired location.

ADJUSTMENT RANGE

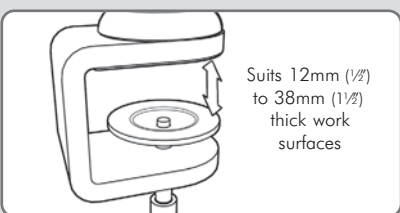

NOTE: It is recommended that the Pole Assembly be clamped to the rear or side edge of the work surface

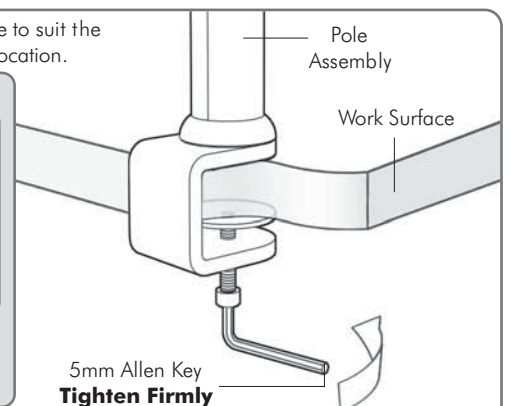

C Assemble the Double Arm Assembly onto the Pole Assembly

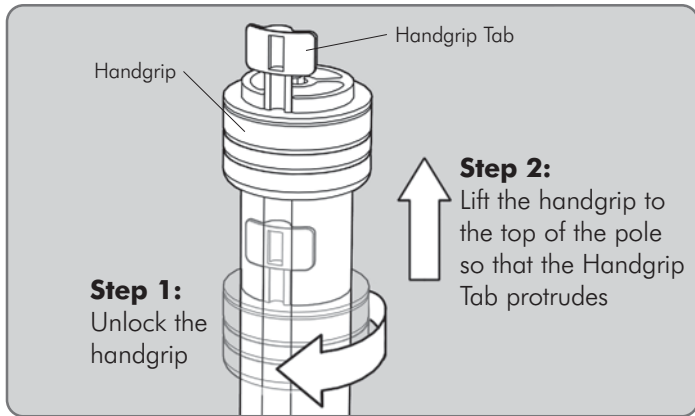

Step 2:
Lift the handgrip to the top of the pole so that the Handgrip Tab protrudes

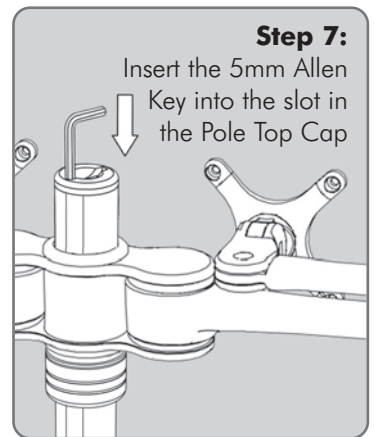
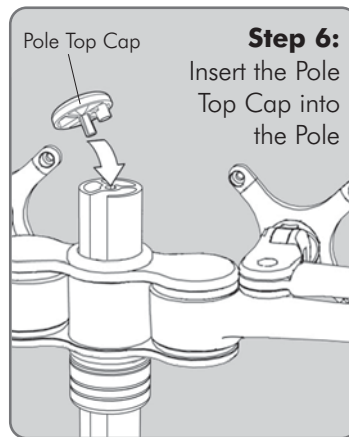
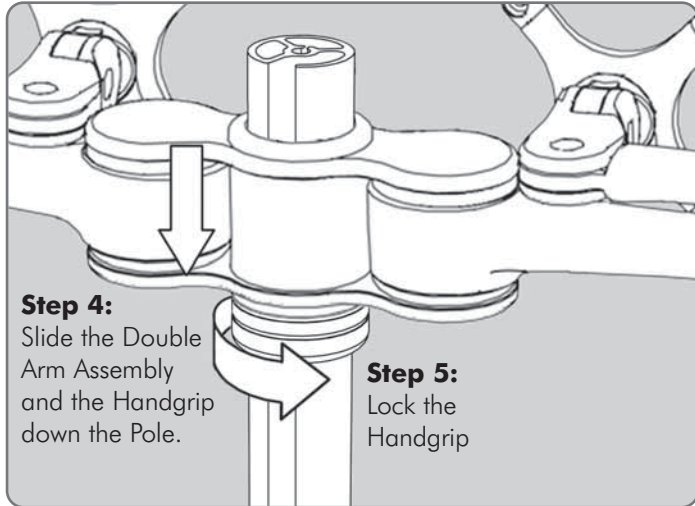
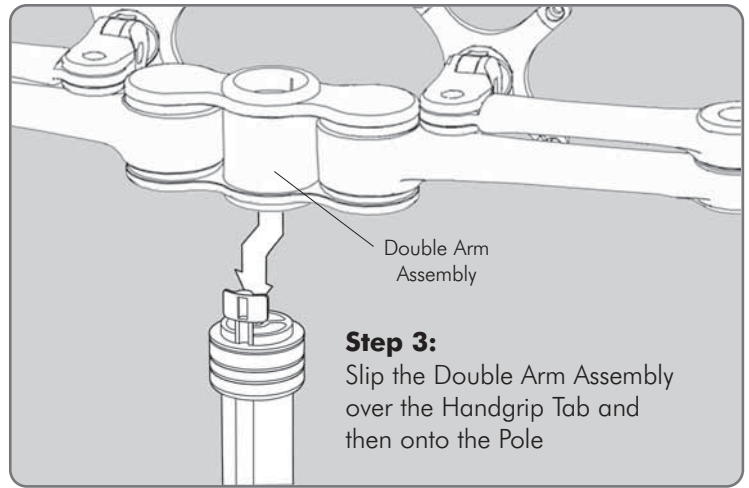

D Mount the Display

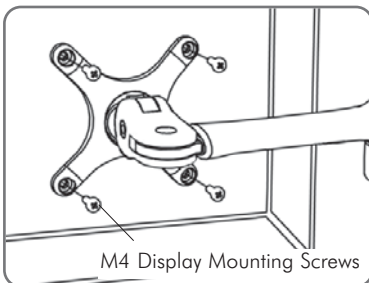

For Displays with 75mm x 75mm (3" x 3") mounting hole patterns

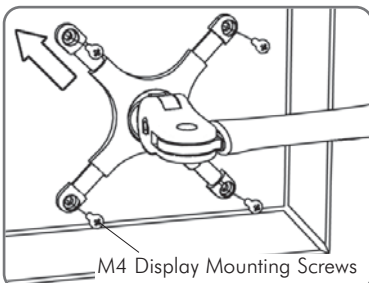

For Displays with 100mm x 100mm (4" x 4") mounting hole patterns

E Cable Management - Make sure arms are fully extended before connecting cables

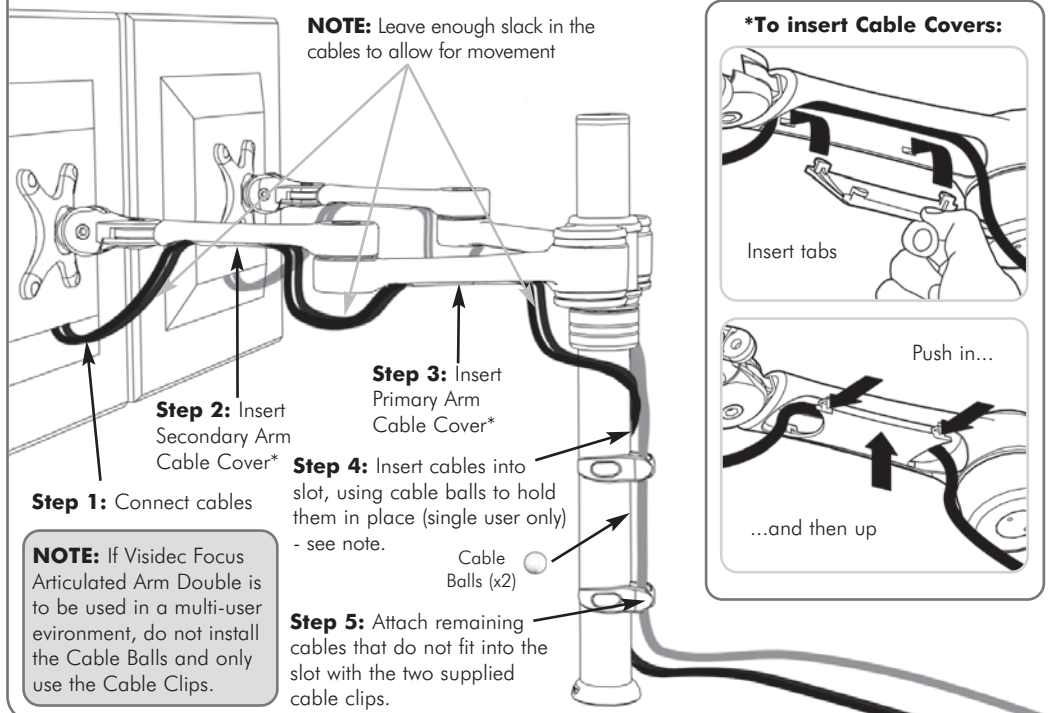

F Leave the "User Operating Card" with Visidec Focus Articulated Arm Double

Leave the "User Operating Card" secured to the base of Visidec Focus Articulated Arm Double with the "atdec" logo facing upwards.

