

**IMPORTANT:**  
The "User Operating Card" must be left with Visidec Focus Articulated Arm once installed

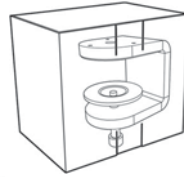

# VF-AT / FOCUS ARTICULATED ARM Installation Instructions

## A Component Checklist - Check you have received all parts against the component checklist prior to installing

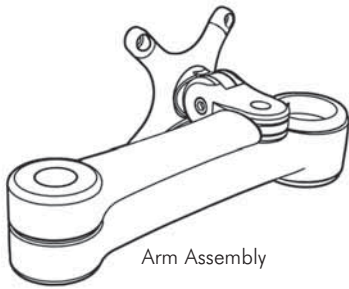

### Desk Clamp Box

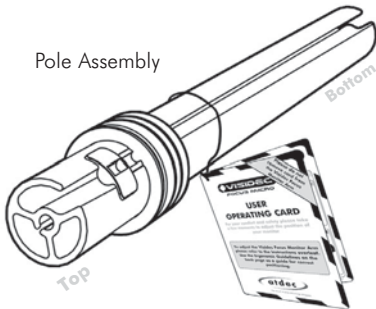
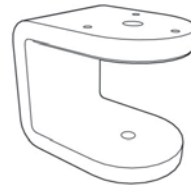

**User Operating Card**  
(see note at top of page)

### Bits Box



### Display Mounting Screws

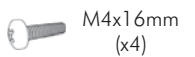
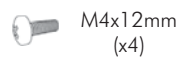
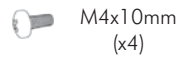

## B1 Bolt Through

OR

## B2 Desk Clamp

Drill a 9mm (3/8") hole in the Work Surface at the desired position and assemble as shown below.

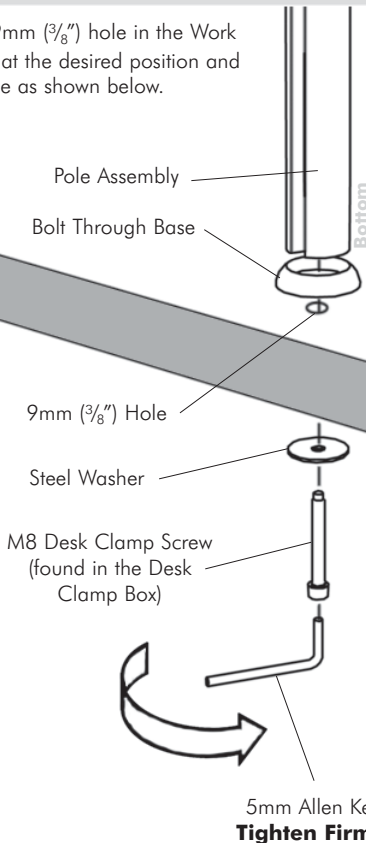

**Step 1:** Attach the Desk Clamp Bracket to the bottom of the Pole Assembly using the M8x30mm Screw. **Tighten firmly** using the 5mm Allen Key. Ensure the Visidec logo is facing the front as shown.

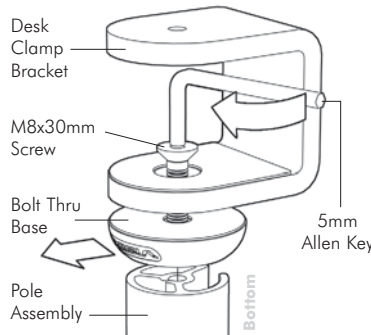

**Step 2:** Install the M8 Desk Clamp Screw and Pressure Plate as shown.

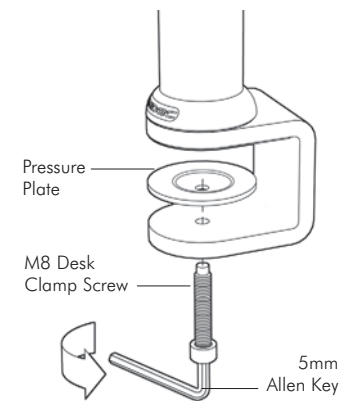

**Step 3:** Adjust the height of the Pressure Plate to suit the Work Surface and Tighten Firmly in the desired location.

### ADJUSTMENT RANGE

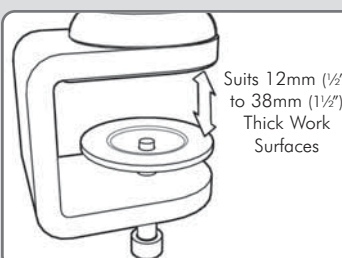

**NOTE:** It is recommended that the Pole Assembly be clamped to the rear or side edge of the Work Surface

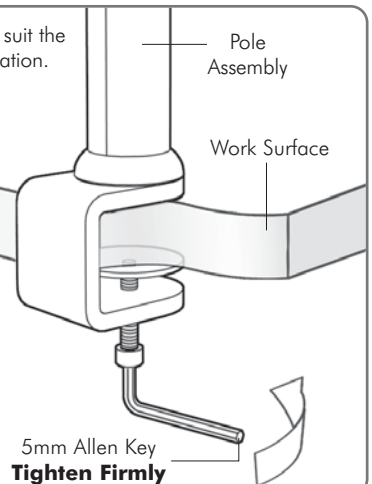

**NOTE:** It is recommended that the Pole Assembly be mounted towards the rear edge of the Work Surface

## C Assemble the Arm Assembly onto the Pole Assembly

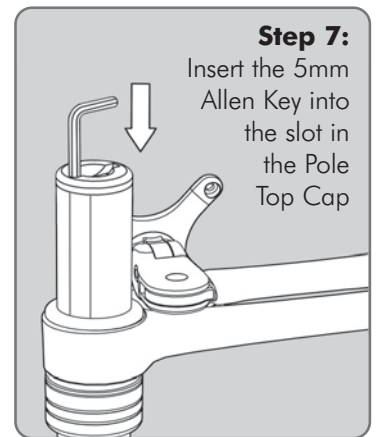
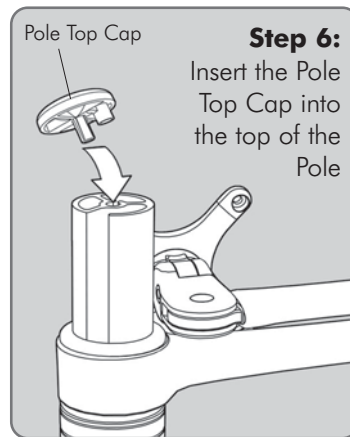
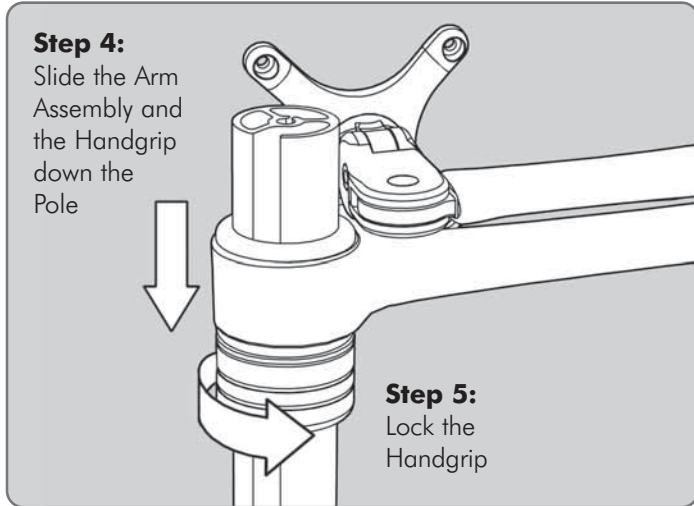
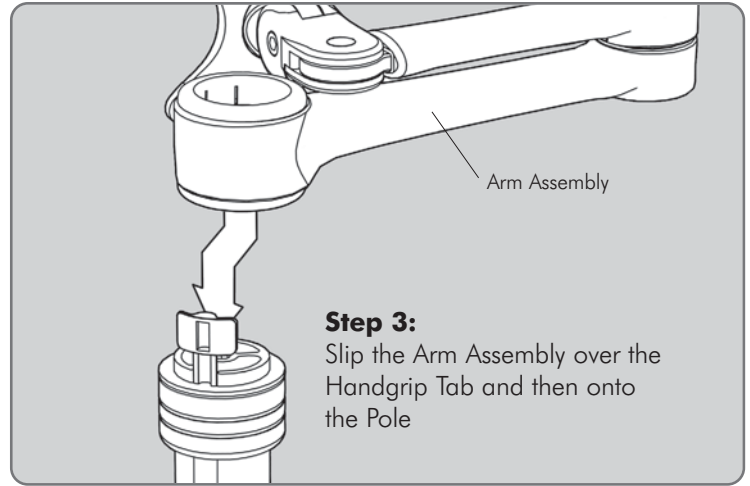
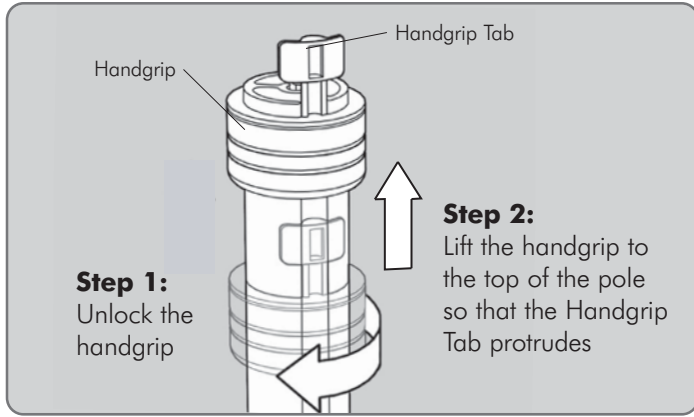

## D Mount the Display

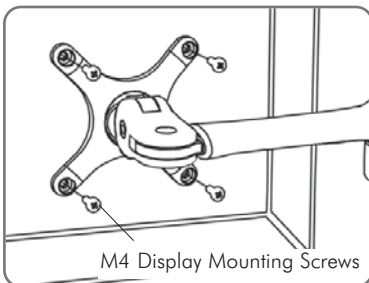

For Displays with 75mm x 75mm (3" x 3") mounting hole patterns

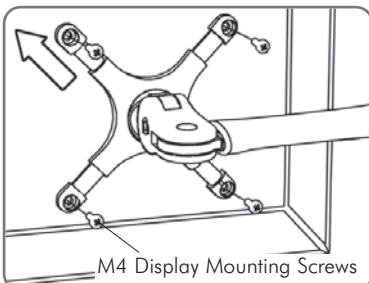

For Displays with 100mm x 100mm (4" x 4") mounting hole patterns

## E Cable Management - Ensure arm is fully extended before connecting cables

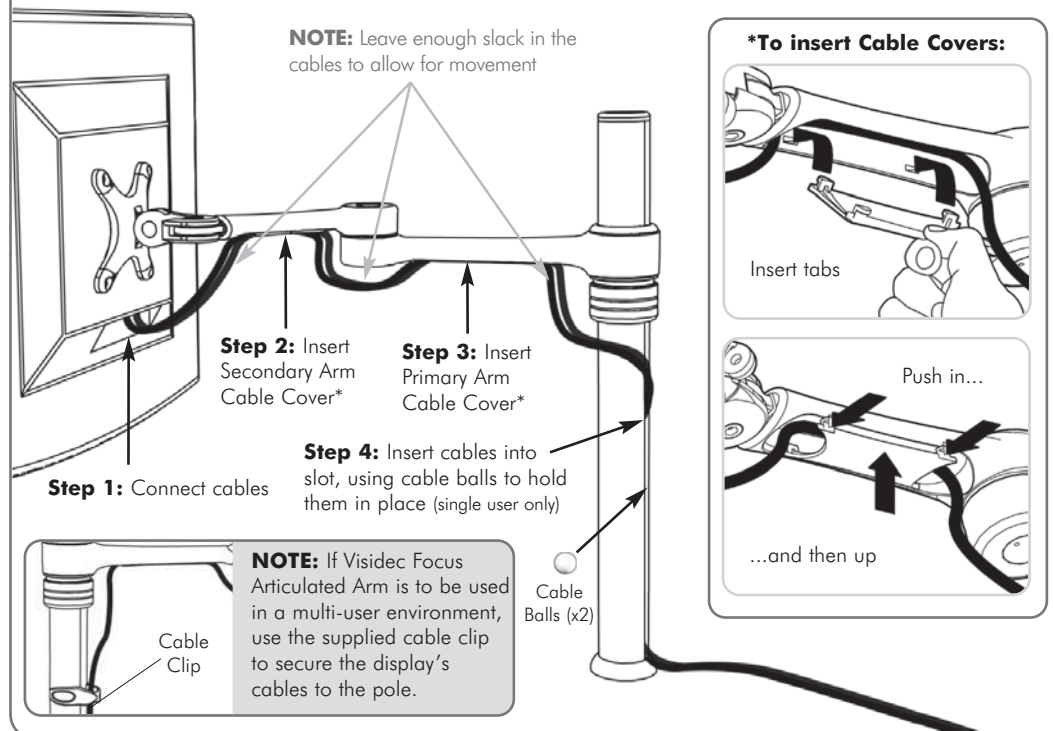

## F Leave the "User Operating Card" with Visidec Focus Articulated Arm

Leave the "User Operating Card" secured to the Visidec Focus Articulated Arm for the user's reference.

