



Full Motion | Large swing arm TH-3060-SAU

- Suits mounting hole patterns 180-685mm (7-27") W x 100-430mm (4-17") H
- Flexible wall mount
- Suits displays up to 65kgs (143lbs)
- Swing arm wall extension
- Adjustable tilt and pan
- Detachable mounting head
- Allows horizontal position adjustment
- Enhanced security

The Telehook Large Swing Arm is a flexible wall mount which combines a high weight capacity with superior operational flexibility and enhanced security support. The Full Motion design allows the display to be extended from the wall and rotated to the required viewing position. The removable display bracket features Universal mounting hole support for compatibility with the widest range of monitors and television screens. The bracket allows fine levelling adjustment and supports locking for added security with public area installation. Once installed you're guaranteed a quality professional finish with a sleek look and a stylish dress cover that hides the wall plate.



### Product key features:

- Suits a wide range of installation and usage situations
- Swing design enables wall extension from 100mm (4") to 554mm (22")
- Allows 180° rotation at the wall and 180° at the display head
- Detachable mounting head enables easy installation and maintenance with support for physical locking (lock not included)
- Allows tilt adjustment from -5° to +25°.
- Allows +/-5° horizontal adjustment for screen levelling
- Comes with mounting hardware to enable masonry or timber stud wall installation
- Durable construction with 10 year warranty

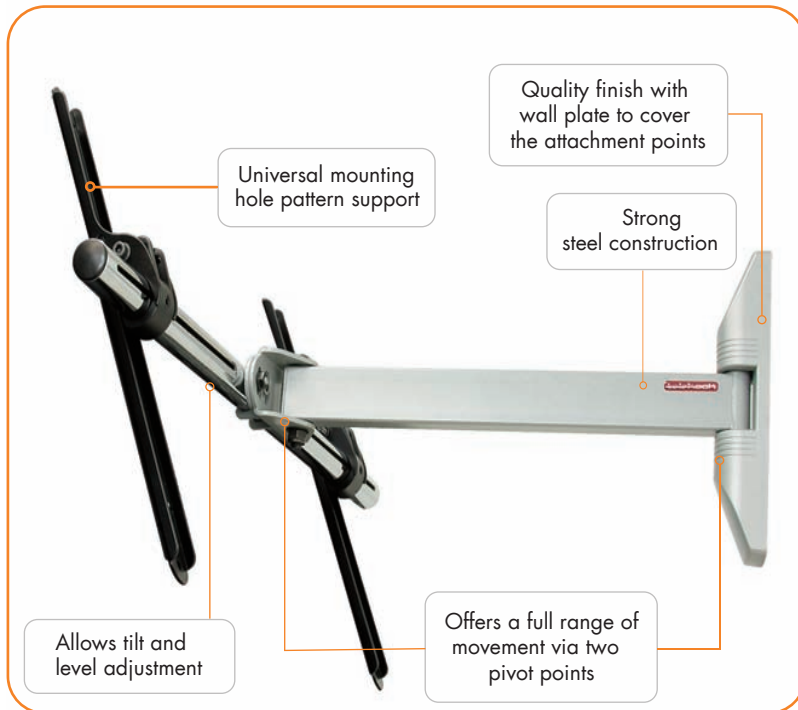

Removable mounting head



Atdec Global [www.atdec.com.au](http://www.atdec.com.au)  
Atdec North America [www.atdec.com](http://www.atdec.com)

## Product information, single unit

| Model code  | Load capacity | Material  | Color                                    |
|-------------|---------------|---|--|
| TH-3060-SAU | 65kg (143lbs) | All steel construction with chrome & powder-coat finish, plastic trim | Matt/polished silver with black brackets |

## Package information, single unit

| Size (W x H x D)                           | Ship weight     | UPC code     | Contents  |
|--|-----------------|--------------|---|
| 840 x 330 x 70mm<br>(32.8" x 12.9" x 2.7") | 7.5kg (16.5lbs) | 881493004801 | Mount (pre-assembled) with wall cover, security screw, install guide, install templates, display and wall attachment hardware |

## Package information, master pack

| Size (W x H x D)       | Ship weight    | UPC          | Units per master pack |
|------------------------|----------------|--------------|-----------------------|
| (33.9" x 13.7" x 6.6") | 16kg (35.2lbs) | 881493004870 | 2                     |

## Technical drawings

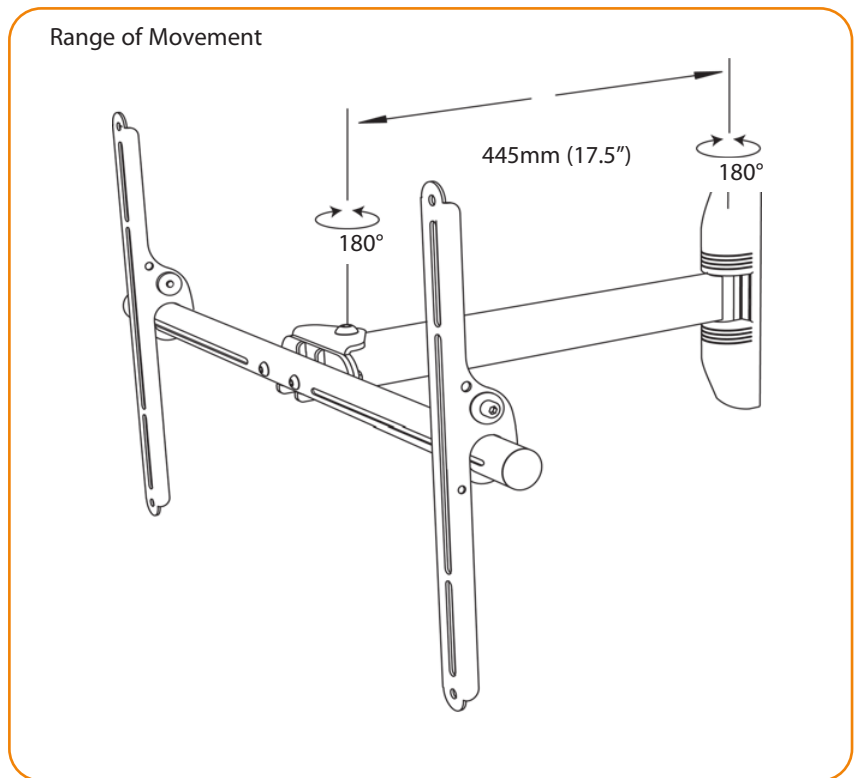
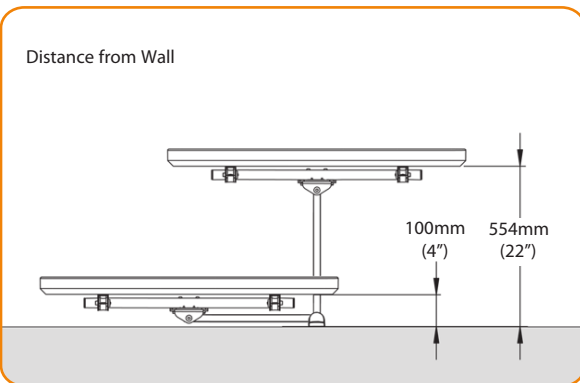
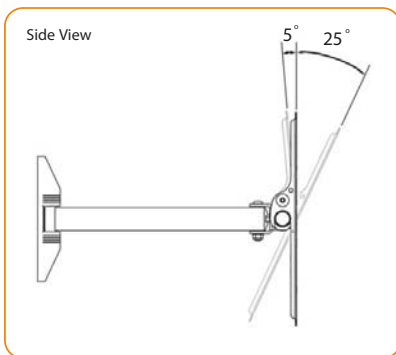

## Other models in this range

|            |   |
|------------|---|
| TH-1032-VF | Low weight Full Motion swing arm          |
| TH-1040-VF | Low weight Full Motion articulated arm    |
| TH-2050-VF | Medium weight Full Motion articulated arm |
| TH-3270-UF | High weight articulated arm               |

Atdec mounts are designed, developed and tested in Australia. We manufacture an extensive range of display and projector mountings for a variety of user types and situations. While all efforts have been made to ensure the information in this brochure was correct as of the date of printing, we reserve the right to change specifications without notice. Please refer to the web site for our full range along with the latest details on specifications, compatibility and dealer location. Atdec and Telehook are registered trademarks with all rights reserved.  
Copyright July 2011 V2.0



Atdec Global [www.atdec.com.au](http://www.atdec.com.au)  
Atdec North America [www.atdec.com](http://www.atdec.com)