

F Attaching the Flush Mount Assembly to the Ceiling Plate

F.1.

Connect the Shaft to the Ceiling Plate as shown below.

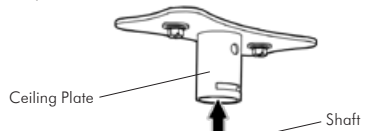

F.2.

Insert the Locking Hook into the slot in the Ceiling Plate to lock the Flush Mount Assembly.

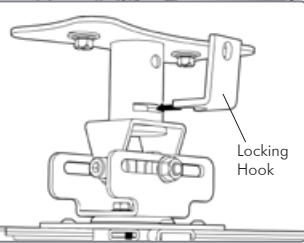

F.3.

Tighten the Locking Hook with the M8x50mm Socket Cap Screw and the M8 Nyloc Nut that was previously removed.

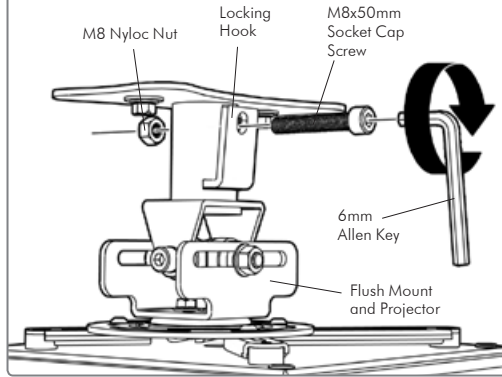

Tip: When the projector requires servicing, remove the projector via this easy disconnection point to save time.

IMPORTANT

Please read these instructions before commencing installation as faulty installation could result in injury. Atdec assumes no responsibility for faulty installations.

Installation Instructions

TELEHOOK

UNIVERSAL PROJECTOR FLUSH MOUNT

WARNING: This bracket supports up to 15kg (33lbs). DO NOT overload this bracket.

Component Checklist

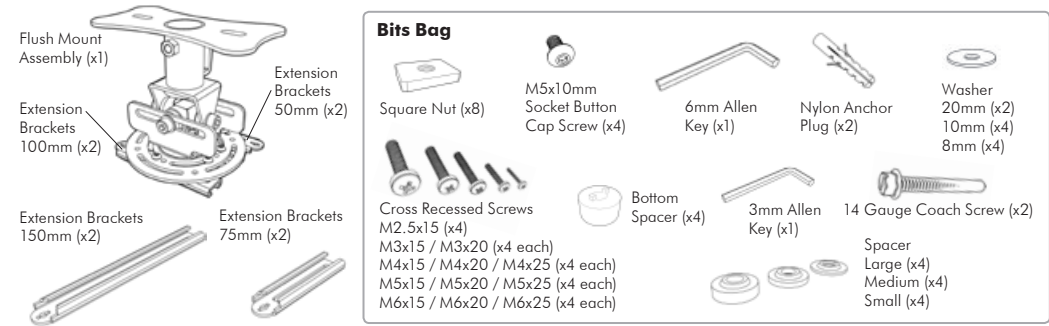

G Adjusting the Projector

Roll / Shift Adjustment

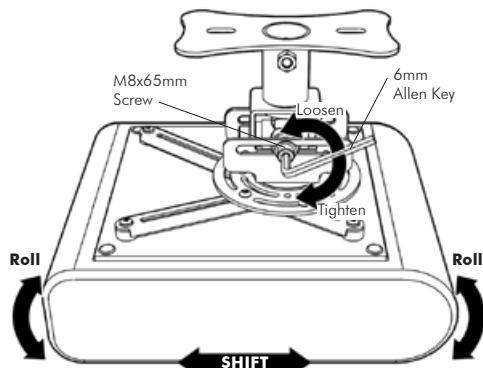

To make Roll/Shift adjustments, first ensure the weight of the projector is supported. Then loosen the M8x65mm Screw with the supplied 6mm Allen Key, and adjust to your desired position. Re-tighten the screw firmly.

Pitch Adjustment

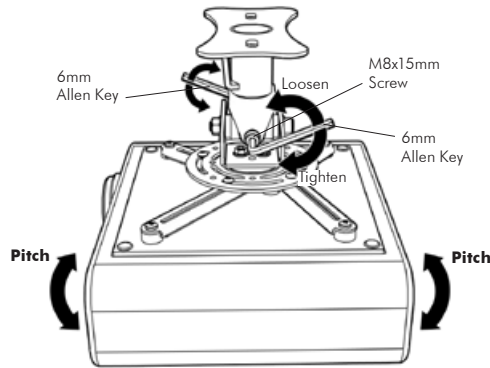

To make Pitch adjustment, first ensure the weight of the projector is supported. Then loosen both M8x15mm Screws with the supplied 6mm Allen Key, and adjust to your desired position. Re-tighten both screws firmly.

WARNING

- Ensure the Ceiling can support the total weight of the Projector and the Universal Flush Mount.
- All bolts and screws must be used at the designated points in the installation instructions to prevent damage to the projector, or personal injury.
- **DO NOT** install near air conditioner vents or where there is excessive dust or smoke.
- Ensure the projector is mounted so that it is not possible for excessive loads to be placed on the bracket.

A Component Checklist

Check you have received all parts against the Component Checklist above.

B Removing the Ceiling Plate from the Flush Mount Assembly

Remove the Ceiling Plate from the Flush Mount Assembly as shown.

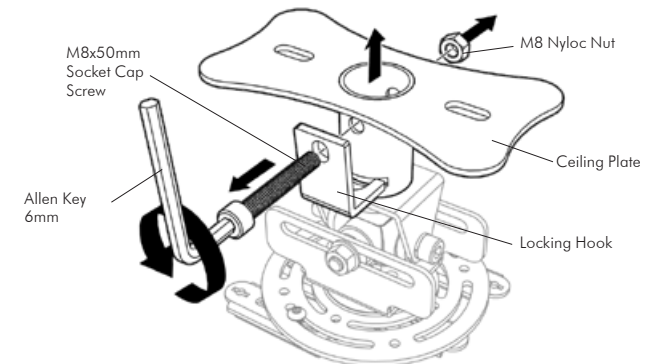

Installation Complete



C Installing the Ceiling Plate

Choose the appropriate installation procedure depending on your ceiling type.

Masonry

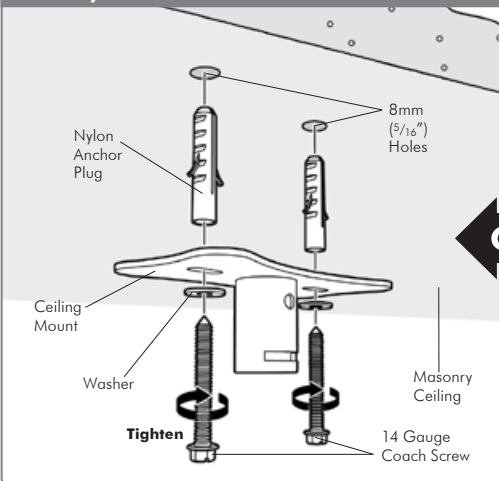

OR

Plaster Board

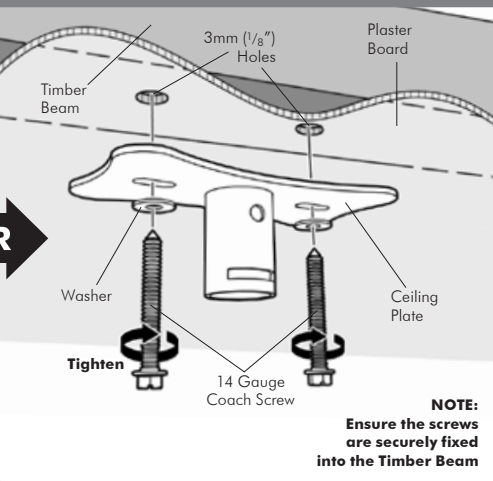

E.2.

Place the Flush Mount Assembly over the Projector and align the centre of the Flush Mount with the Centre of Gravity marked previously on the Projector.

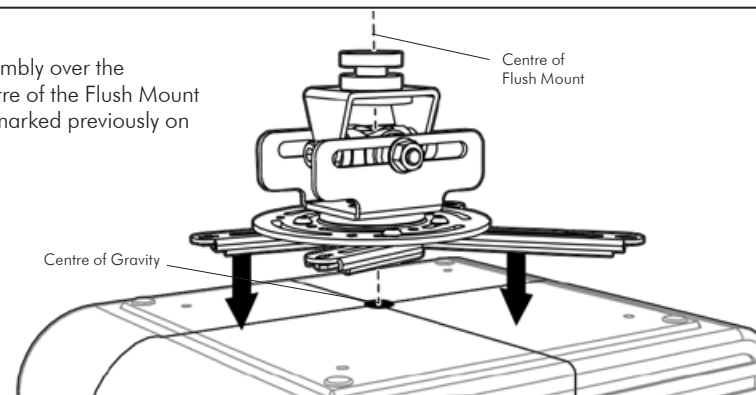

E.3.

Place the Bottom Spacers in between the Extension Brackets and the Projector, and align the mounting holes as shown below.

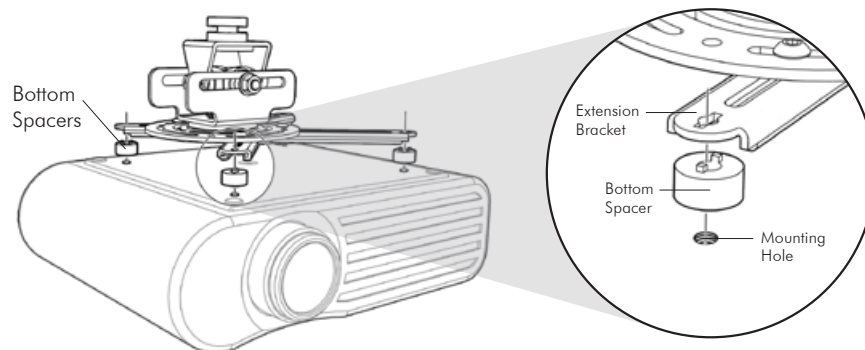

NOTE

If your mounting holes are recessed into the projector, you may need to use the additional Spacers supplied in the Bits Bag. Please select the appropriate Spacers according to the design of your projector.

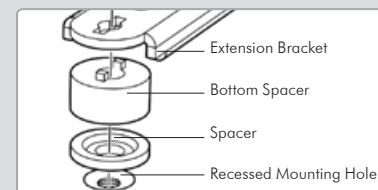

D Finding the Center of Gravity of the Projector

D.1.

Pick up the projector using both of your index fingers. Move your fingers along the side of the Projector (follow Step 1) until it is level. Remember the balance point.

D.2.

Repeat this process for the perpendicular side (follow Step 2)

D.3.

Where both balance points meet is the Centre of Gravity of your projector. Use a pencil to mark this point.

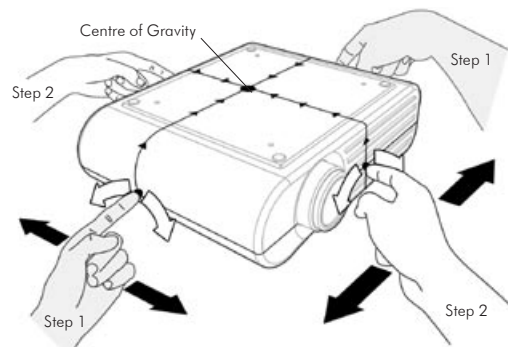

E Attaching the Flush Mount Assembly to the Projector

E.1.

Loosen the M5x10mm Screws using the supplied 3mm Allen Key until you can slide the extension brackets freely, as shown.

OR

You may need to replace the attached Extension Brackets with the additional longer brackets supplied in the package, to suit the mounting hole configuration of your projector.

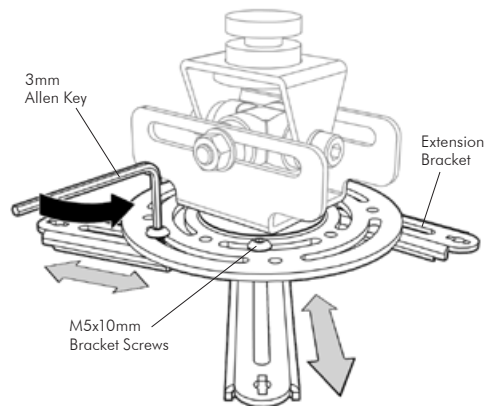

E.4.

Select the correct Mounting Screws from the Bits Bag and firmly screw the Flush Mount Assembly onto your Projector.

Once this is done, the Projector Flush Mount Assembly is ready to be mounted onto the Ceiling Plate.

