

G Installing Cable Management

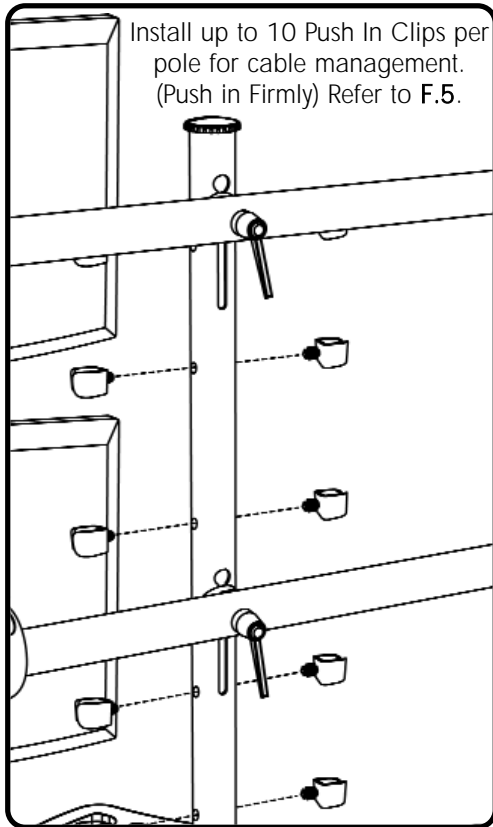

G.1.

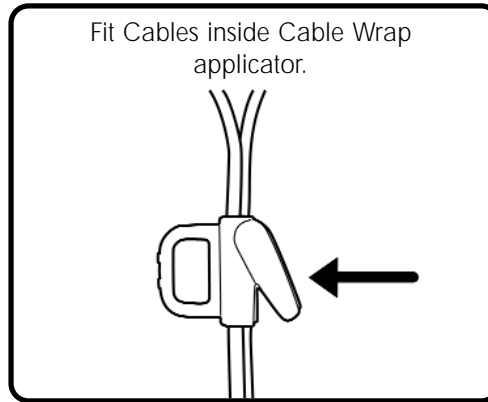

G.2.

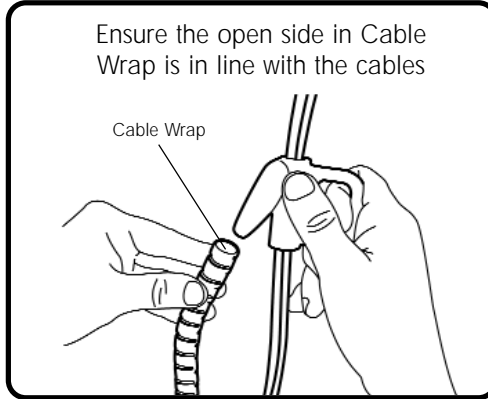

G.3.

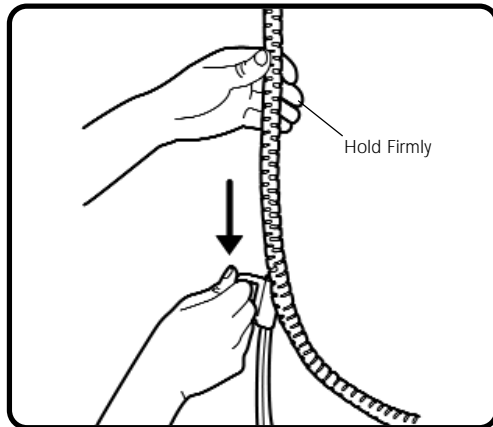

G.4.

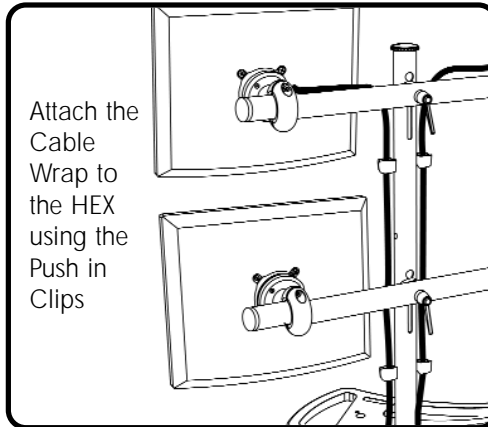

G.5.



Installation Instructions

SPACEDEC™

DISPLAY

Freestanding Hex

Component Checklist

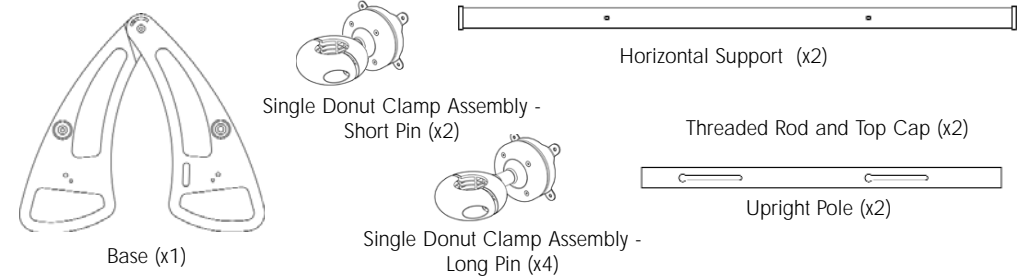

Bit Bag

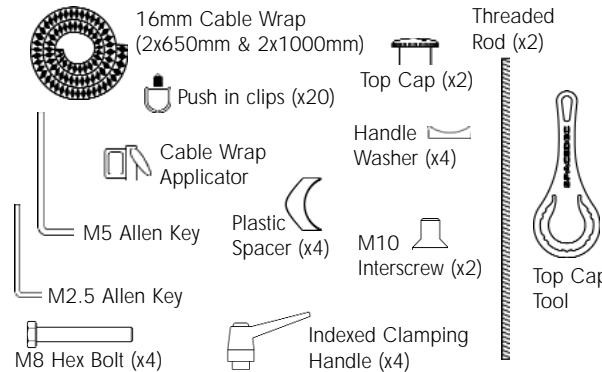

Direct Mount Bit Bag

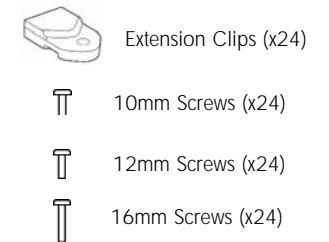

A Fitting the Donut Clamps to the Horizontal Supports

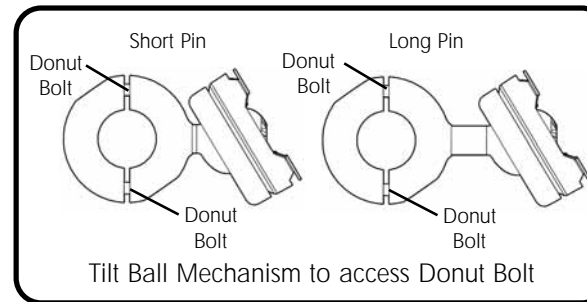

A.1.

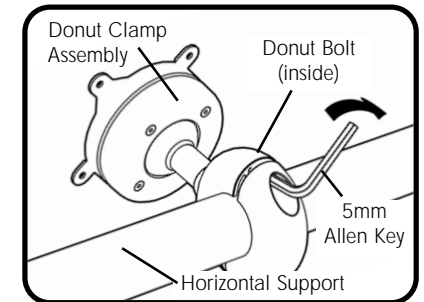

A.2.

Loosen both Donut Bolts evenly using Allen Key supplied. Slide Donut Clamps over each Horizontal Support and re-tighten lightly, as these will need to be repositioned later.

WARNING : DO NOT OVER TIGHTEN!

Install the Short Pin donuts in the centre of each Horizontal Support and the Long Pins to the ends to allow a concave display configuration.

B Install the Upright Poles

Attach the Top Caps to the Threaded Rods by turning the Top Caps Clockwise until tight.

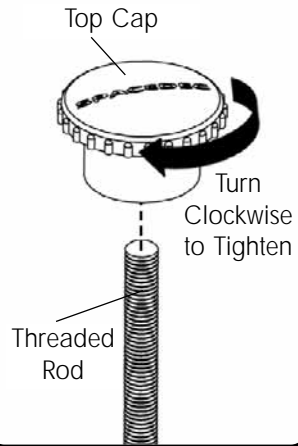

B.1.

Attach Poles to Base using the Threaded Rod and M10 Interscrews. Tighten Poles firmly by holding the M10 Interscrews inside the base with your index finger and tighten using Top Cap Tool. Be sure to locate Poles correctly in circular grooves in base. Ensure that when poles are positioned 525mm apart, the Keyhole Cut-outs are rearward facing.

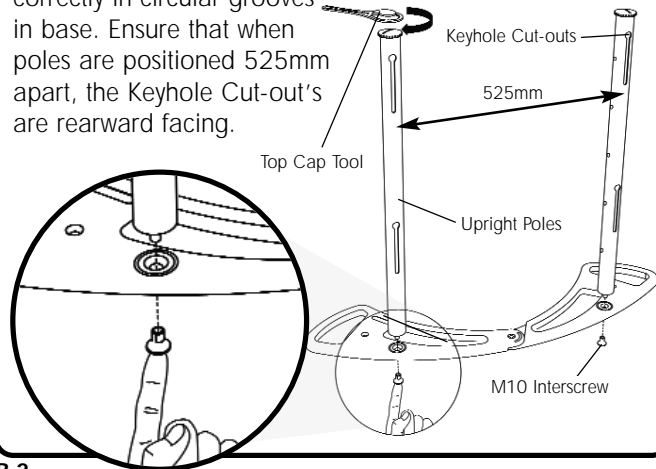

B.2.

C Install the Horizontal Supports

Fit the two Horizontal Supports as Illustrated.

Note: The Red Button on the Clamping Handle can be pressed inward, to allow you to rotate the handle to a vertical position without loosening/further tightening the connection.

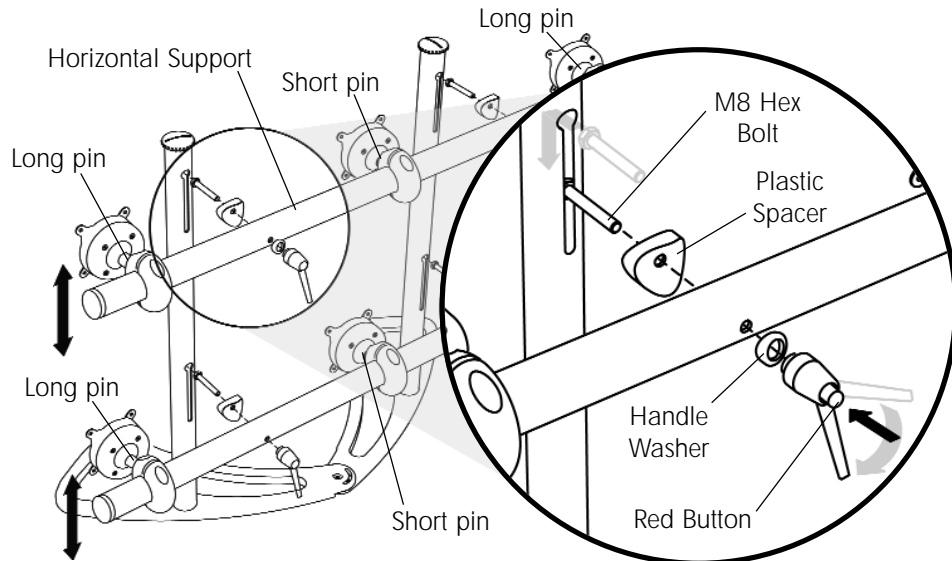

C.1.

D Adjusting the Horizontal position of the "Donut" Clamps

Loosen screws to adjust the position of each "Donut" Clamp to suit your monitor size/ application.

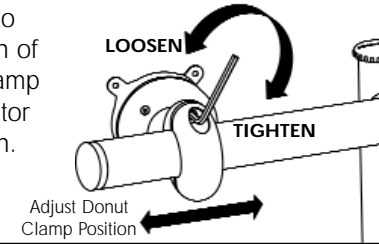

D.1.

Tighten "Donut" Hex screws firmly and evenly.

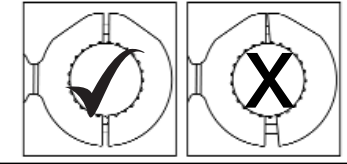

D.2.

E Attaching your Monitors

Direct Mount 75mm VESA

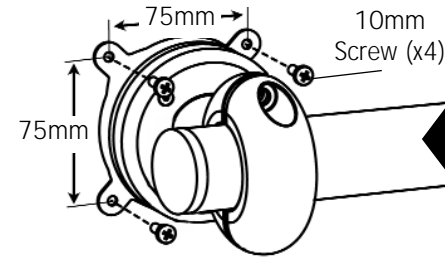

E.1.

Direct Mount 100mm VESA

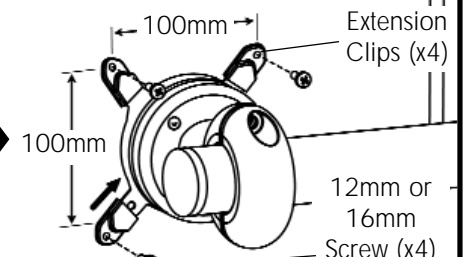

E.2.

F Making Adjustments

Adjust the Ball Joint mechanism to suit the Monitor weight. Tighten or loosen screws ① to ④ evenly, 1/4 turn at a time.

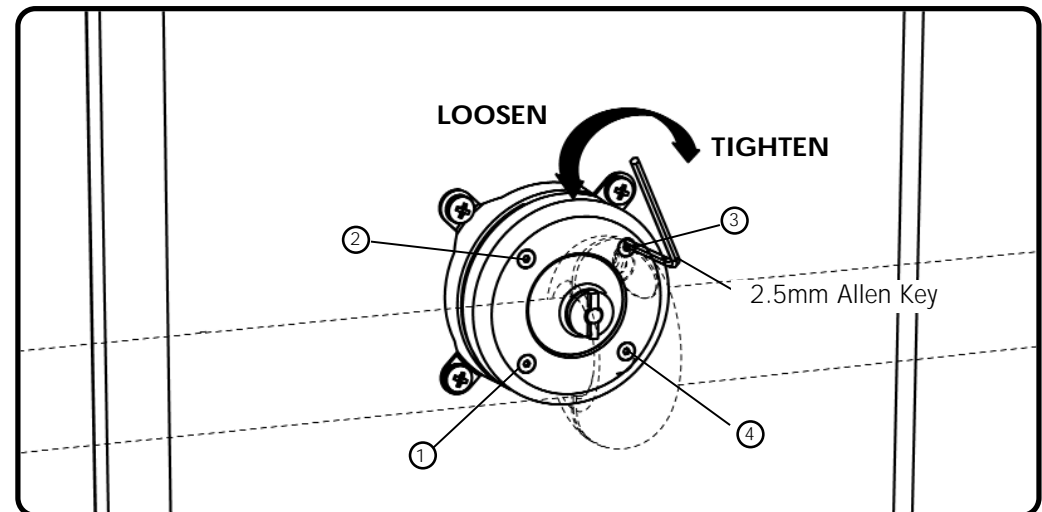

F.1.